

Butterfly Valve Installation and Maintenance Instructions

Safety

Personnel involved in the installation, maintenance or removal of butterfly valves from pipelines should be constantly alert

to potential leakage or emission of process material and take appropriate precautions to insure safety. Valves that have been removed

from service should be handled assuming the presence of process material within the valve. Personnel should be suitably protected.

Installation

Prior to installation, butterfly valves and mating flanges should be inspected to assure gasket surfaces are free of defects. Valves should not be mounted between flanges having defective gasket surfaces. Piping should be checked for proper alignment. Lugged butterfly valves should never be used to align improperly positioned piping. The distance between pipe flanges should be checked to assure sufficient clearance for valve installation. The valve should be in the closed position when being placed between flanges. For wafer valves, the valve must be visually centered with respect to the flange faces, while lugged valves may be

centered with flange bolting. The valve should be operated to assure that no binding or interference is taking place. Flange boltings should be tightened gradually in a crisscross manner according to the illustration at right. The flange joint is complete after the valve body bottoms against the flange faces evenly such that no gaps exist. Bolting should then be tightened sufficiently to prevent loosening of the joint.

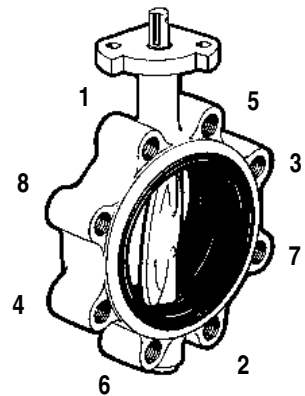

Maintenance

Butterfly valves are designed such that no periodic maintenance or lubrication is required throughout the life of the product. It is, however, recommended that the following practices be followed on at least a monthly basis:

- (1) Operate the valve from full open to closed to assure operability.
- (2) Check fasteners for evidence of loosening and correct as required.
- (3) Inspect valve and surrounding area for previous or existing leakage at flange faces or stem connections.
- (4) Check piping and/or wiring to actuators and related equipment for looseness, corrosion or defects and correct as required.

Removal of Valve from Pipeline

Prior to loosening the flange bolts (valve in open position):

- (1) Drain piping run as much as possible.
- (2) Vent line to relieve pressure.

Close valve, then:

- (1) Disconnect air/electric lines from actuator and tag for reinstallation.
- (2) Loosen flange bolts to decompress valve gasket seals.

(Caution: Be alert to emission of process material from pipeline.)

- (3) Secure necessary lifting equipment to valve assembly.
- (4) Remove flange bolting and carefully remove valve from between pipe flanges.