

SUBMITTAL DATA

18" DIA. WATER TO WATER
U-TUBE HEAT EXCHANGER

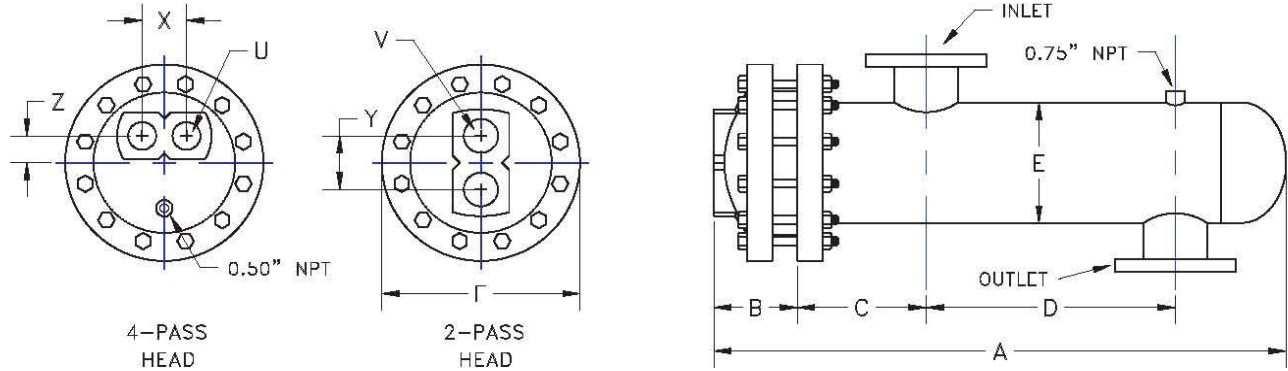

Model No.	HEAT EXCHANGER								2 PASS		4 PASS				
	A	B	C	D	E	F	INLET	OUTLET	Y	V	SQ. FT.	X	Z	U	SQ. FT.
W1836(*)A	54.02	5.58	11.00	24.00	18.00	25.00	4" FLG	4" FLG	10.50	6" NPT	137	8.00	3.88	5" NPT	132
W1848(*)A	66.02			36.00							184				178
W1860(*)A	78.02			48.00							232				224
W1872(*)A	90.02			60.00							280				271
W1884(*)A	102.02			72.00							328				317
W1896(*)A	114.02			84.00							376				363
W18108(*)A	126.02			96.00							424				410
W18120(*)A	138.02			108.00							472				456

(*) INSERT NUMBER OF PASSES

DESIGNED & CONSTRUCTED PER ASME SECT VIII DIV 1

MATERIALS OF CONSTRUCTION

PART	STANDARD	OPTIONAL
HEAD	CAST IRON	** FAB C.S. OR S.S.
SHELL	STEEL	S.S.
TUBE SHEET	STEEL	BRASS*** OR S.S.
TUBING	3/4" OD 20 ga Copper	18 ga. Copper, 304 S.S., 316 S.S. 90/10 CU/NI, OR 16 Ga. C.S.
CAGE MATERIAL	STEEL	BRASS OR S.S.
BAFFLES	STEEL	BRASS OR S.S.

*** NOT SHOWN ON THIS SHEET

MAXIMUM OPERATING CONDITIONS

	HEAD STYLE	
	CAST IRON	FABRICATED ** C.S. OR S.S.
TUBE SIDE WORKING PRESSURE	125 PSI	150 PSI
SHELL SIDE WORKING PRESSURE	150 PSI	150 PSI
HYDROSTATIC TEST PRESSURE TUBE SIDE	250 PSI	300 PSI
HYDROSTATIC TEST PRESSURE SHELL SIDE	195 PSI	195 PSI
MAXIMUM TEMPERATURE TUBE SIDE***	375°F	375°F
MAXIMUM TEMPERATURE SHELL SIDE***	375°F	375°F

***DERATE TO 300°F WITH BRASS TUBESHEET

Job Name _____
 Location _____
 Engineer _____
 Architect _____
 Sales Rep. _____
 Contractor _____

Model No. Ordered

	Tube Side	Shell Side
Flow (GPM)		
Ent. Temp.		
Leav. Temp.		
Fouling Factor		