

SUBMITTAL DATA

6" DIA. WATER TO WATER
U-TUBE HEAT EXCHANGER

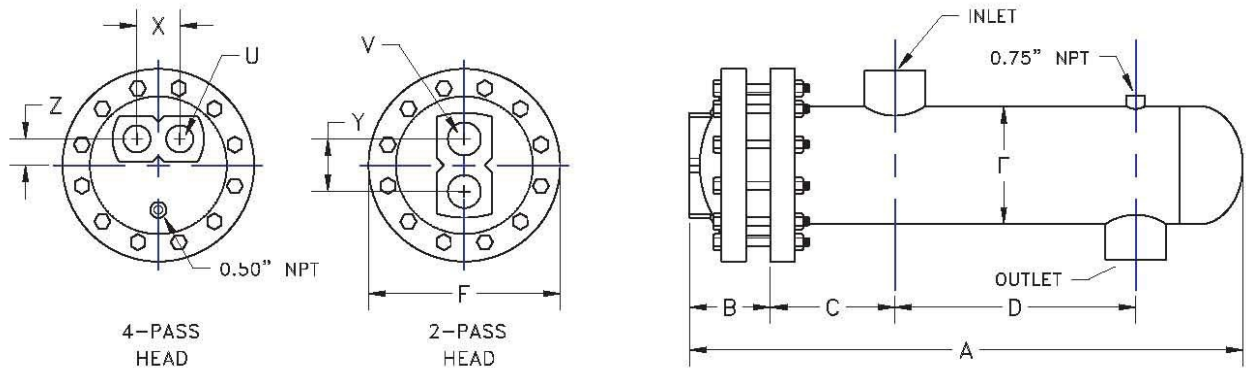

Model No.	HEAT EXCHANGER								2 PASS		4 PASS				
	A	B	C	D	E	F	INLET	OUTLET	Y	V	SQ. FT.	X	Z	U	SQ. FT.
W624(*)A	30.01			12.75							8				8
W636(*)A	42.01			24.75							12.8				12.8
W648(*)A	54.01			36.75							17.6				17.6
W660(*)A	66.01			48.75							22.4				22.4
W672(*)A	78.01	3.13	6.00	60.75	6.63	11.00	3" NPT	3" NPT	3.75	2" NPT	27.1	2.69	1.25	1.5" NPT	27.1
W684(*)A	90.01			72.75							31.9				31.9
W696(*)A	102.01			84.75							36.7				36.7
W6108(*)A	114.01			96.75							41.5				41.5
W6120(*)A	126.01			108.75							46.3				46.3

(*) INSERT NUMBER OF PASSES

DESIGNED & CONSTRUCTED PER ASME SECT VIII DIV 1

MATERIALS OF CONSTRUCTION

PART	STANDARD	OPTIONAL
HEAD	CAST IRON	CAST BRONZE OR CAST S.S.
SHELL	STEEL	S.S.
TUBE SHEET	STEEL	BRASS*** OR S.S.
TUBING	3/4" OD 20 ga Copper	18 ga. Copper, 304 S.S., 316 S.S. 90/10 CU/NI, OR 16 Ga. C.S.
CAGE MATERIAL	STEEL	BRASS OR S.S.
BAFFLES	STEEL	BRASS OR S.S.

MAXIMUM OPERATING CONDITIONS

TUBE SIDE WORKING PRESSURE	150 PSI
SHELL SIDE WORKING PRESSURE	150 PSI
HYDROSTATIC TEST PRESSURE TUBE SIDE	300 PSI
HYDROSTATIC TEST PRESSURE SHELL SIDE	195 PSI
MAXIMUM TEMPERATURE TUBE SIDE***	375°F
MAXIMUM TEMPERATURE SHELL SIDE***	375°F

***DERATE TO 300°F WITH BRASS TUBESHEET

Job Name _____
 Location _____
 Engineer _____
 Architect _____
 Sales Rep. _____
 Contractor _____

Model No. Ordered

	Tube Side	Shell Side
Flow (GPM)		
Ent. Temp.		
Leav. Temp.		
Fouling Factor		