



WFA Series

ASME Bladder Expansion Tank

Full Acceptance

Features:

- Constructed in accordance with ASME Section VIII, Division I, Latest Edition
- Heavy Duty Butyl Bladder - NSF 61 Approved - Field Replaceable
- Fully Adjustable Field Air Charging
- Factory Air Charged to 12 P.S.I.
- Primed Exterior

Optional Features:

- Trimmed for Potable Water
- "Bulls Eye" sight glass
- Seismic mounting (clips or legs)
- Higher pressures available upon request
- Tank dimensions will not change
- Painted Exterior, Epoxy Coatings

All packaging materials, thread protectors, plastic plugs and caps must be removed before installation.

Dimensions are subject to change without notice, please confirm actual dimensions with factory at time of order.

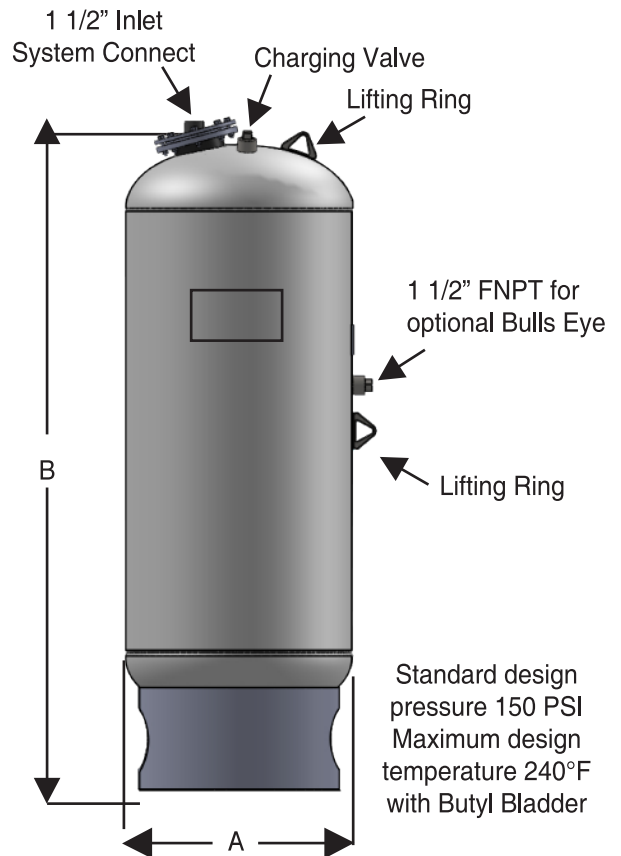

PART NUMBER	ACCEPTANCE VOLUME	DIAMETER A (IN.)	HEIGHT B (IN.)	SYSTEM CONNECT (IN.)	WEIGHT (LBS)	WORKING PRESSURE
WFA-140	36	20"	39 1/2"	1 1/2"	195	150 PSI
WFA-215	57	20"	54"	1 1/2"	290	150 PSI
WFA-300	82	24"	57 1/8"	1 1/2"	320	150 PSI
WFA-450	120	24"	78 3/8"	1 1/2"	400	150 PSI
WFA-600	165	30"	69 3/4"	1 1/2"	450	150 PSI
WFA-800	220	30"	88"	1 1/2"	590	150 PSI
WFA-1000	See 3.250 WFA Large Series					
WFA-1200						
WFA-1400						
WFA-1600						
WFA-2000						



USE:

Designed to absorb expansion of fluids in typical hydronic systems. The WFA Tank is designed for pressure boost systems as well as typical cooling and heating applications. Bladder material is suitable for hot water applications. Installation of the tank will help eliminate constant pump use, prolonging pump life and unnecessary blowing of relief valves.

Specifications:

Furnish and install and shown on plans, American Wheatley WFA series, full acceptance expansion tank. Tank shall be constructed of carbon steel in accordance with ASME Section VIII, Division 1, latest edition. Tank shall incorporate a removable and replaceable heavy duty butyl bladder. Tank shall be supplied with 12 psi factory air charge. Tanks shall be supplied on standard base ring unless otherwise specified. Tanks shall be constructed and ASME stamped for 150 psi working pressure at 240°F. Tanks shall be supplied with exterior high grade red oxide primer finish. Vertical or horizontal installation is acceptable. Non-replaceable diaphragm type tanks are not acceptable.

Typical Piping Details

With Bladder Type Tanks (WFA/WPA Series)

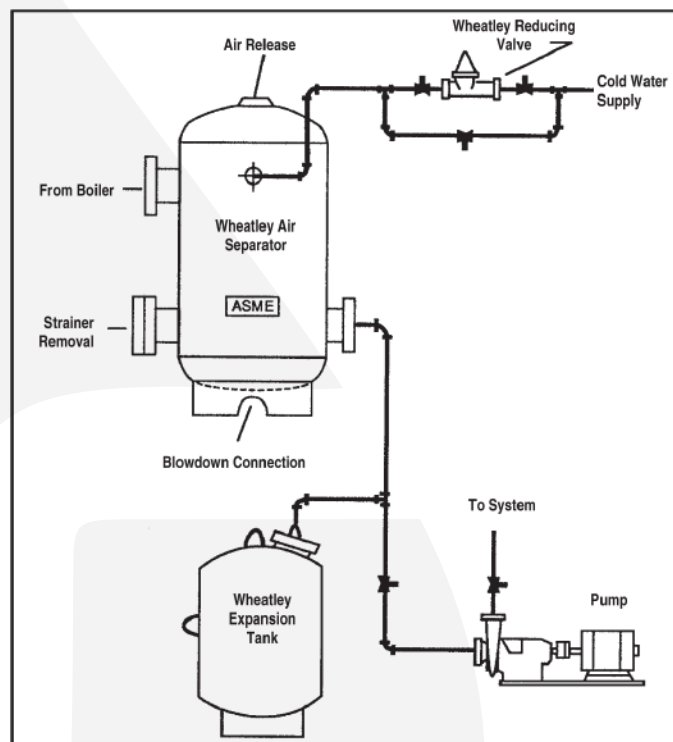

2701 W. Concord Street
Broken Arrow, Ok 74012
Toll Free: 866-204-5229 | PH: 918-317-0401 | FAX: 918-317-0407
www.americanwheatley.com | sales@americanwheatley.com