



Chilled Water Buffer Tank

Features:

- Constructed in accordance with ASME Section VIII, Division I, Latest Edition
- Carbon Steel Construction
- Maximum Temperature 450° F Intermittent
- Design Pressure 125 P.S.I.
- Primed Exterior

Optional Features:

- Manway, Handhole
- Higher Pressures
- Stainless Steel Construction
- Upper Mounted System Connections
- External Coatings
- Insulation / Jacketing*

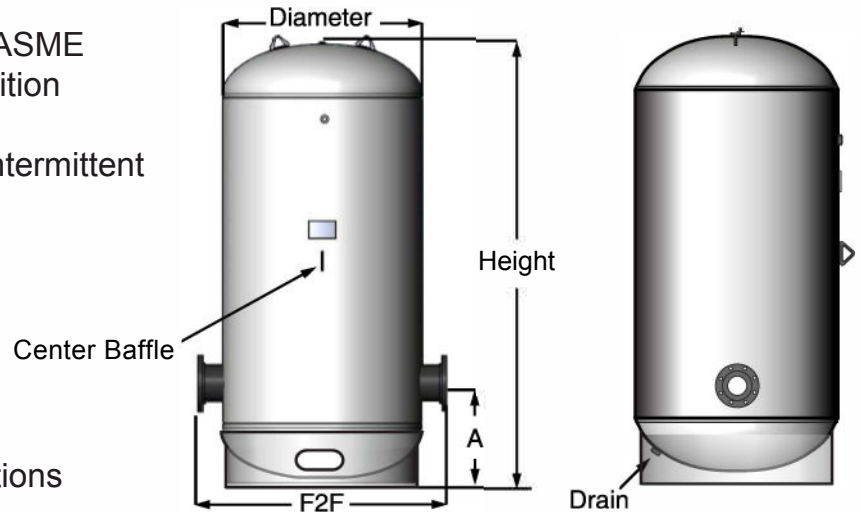

Center-line Height (A in inches) for various Connection*

		DIA.	HGT	2"	2 1/2"	3"	4"	6"	8"	10"	12"	
MODEL	GAL	(IN.)	(IN.)	FLG	FLG	FLG	FLG	FLG	FLG	FLG	FLG	F2F
AWCBT-120	120	24	60	12	12.25	12.50	13	14	15	16	17	36
AWCBT-200	200	30	72	14	14.25	14.50	15	16	17	18	19	42
AWCBT-250	250	30	90	14	14.25	14.50	15	16	17	18	19	42
AWCBT-300	300	36	72	15.75	15.75	16	16.50	17.50	18.5	19.5	20.50	48
AWCBT-400	400	36	99	24	24	24	25	26	27	28	29	48
AWCBT-500	500	42	90	17.50	17.75	18	18.5	19.50	20.5	21.5	22.50	54
AWCBT-750	750	48	106	18.75	19	19.375	19.875	21	21.875	23.5	24.5	
		54	96	21	21.25	21.50	22	23	24	25	26	

DESCRIPTION: American Wheatley ASME Chilled Water Buffer Tanks are designed for chilled water systems with insufficient water volume capacity, in relation to the chiller capacity. Relatively low water volume systems require additional "buffer" capacity for the system to eliminate problems such as excessive chiller cycling, poor temperature control, and erratic system operation. The properly sized American Wheatley CBT tank adds the necessary volume to "buffer" the system.



2701 W. Concord Street
Broken Arrow, Ok 74012

Toll Free: 866-204-5229 | PH: 918-317-0401 | FAX: 918-317-0407
www.wheatleyhvac.com | sales@globalflowproducts.com